

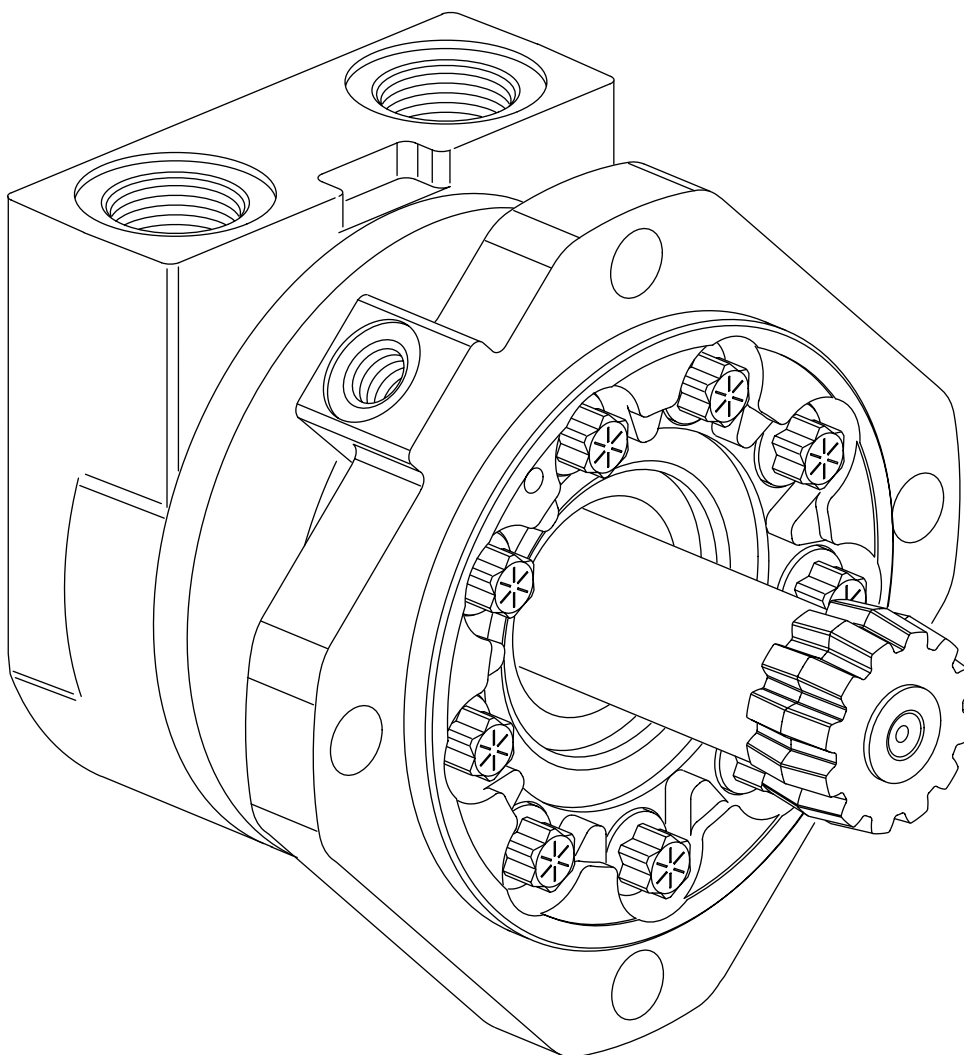

## Repair Information



45 Series  
VIS Bearingless Motor

003

---

## 45 Series Geroler Motors

# 45 Series Geroler Motors

## Disassembly

Shuttle/Relief Valve Parts Shown Enlarged Below

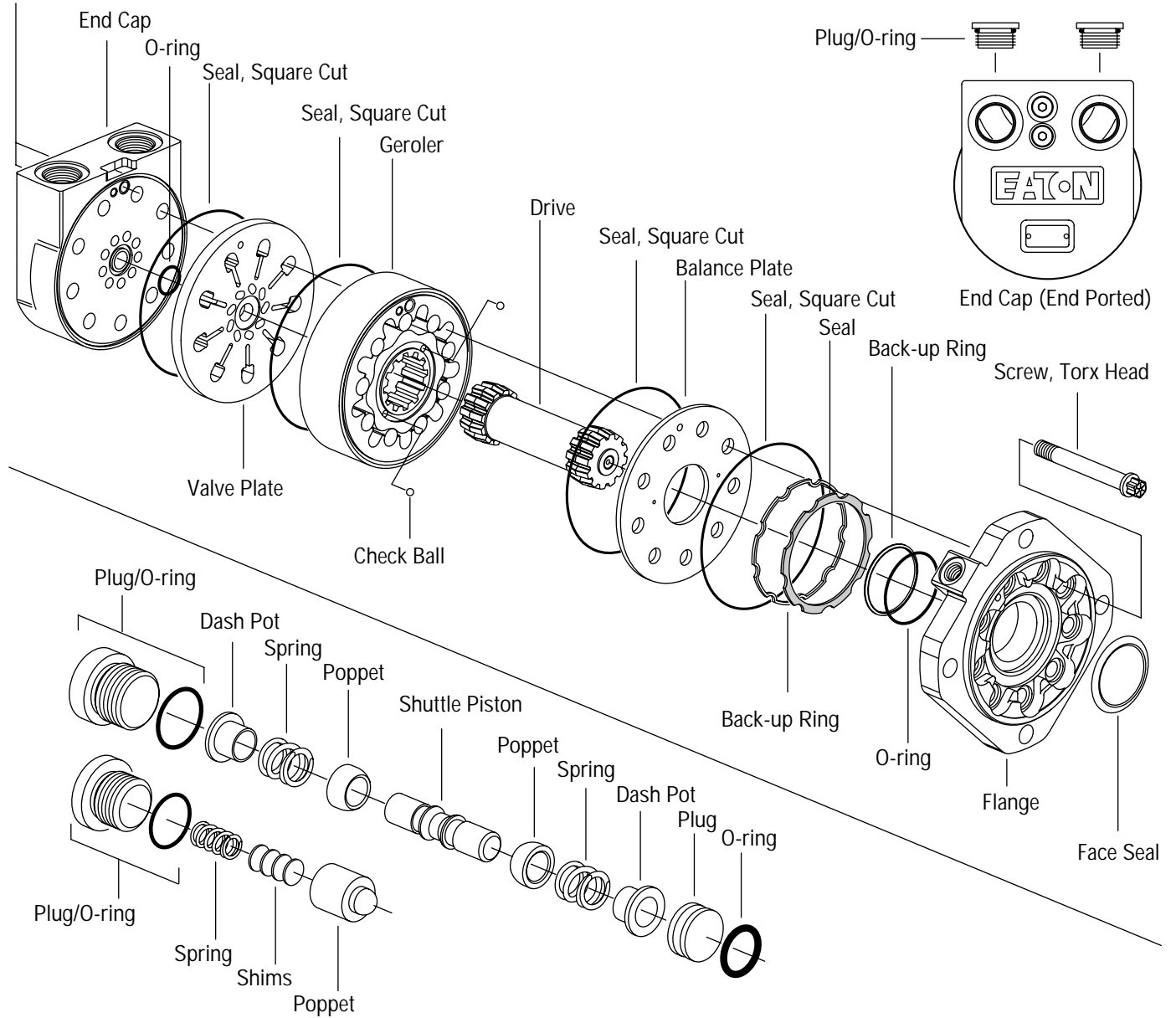

## 45 Series Geroler Motors

### Tools Required

- 1/4 inch Hex Key
- 3/16 inch Hex Key
- 5/8 inch Hex Key (End Ported Motor Only)
- Torque wrench - 200 Nm [150 lb-ft] capacity

### Disassembly

1 Cleanliness is extremely important when repairing hydraulic motors. Work in a clean area. Before disconnecting the hydraulic motor thoroughly clean the exterior. Remove motor from application and drain the oil from the motor before disassembly.

2 Remove the 9 cap screws and disassemble the motor in the vertical position as shown in figures 1 and 2. Note placement of small ball checks in Geroler.

3 Remove shuttle valve (and relief valve if applicable) from end cap.

4 Remove two plugs from end cap, end ported motors only.

5 Check all mating surfaces. To reduce the chance of leakage, replace any parts that have scratches or burrs. Wash all metal parts in clean solvent. Blow them dry with pressurized air. Do not wipe parts dry with paper towels or cloth as lint in a hydraulic system will cause damage.

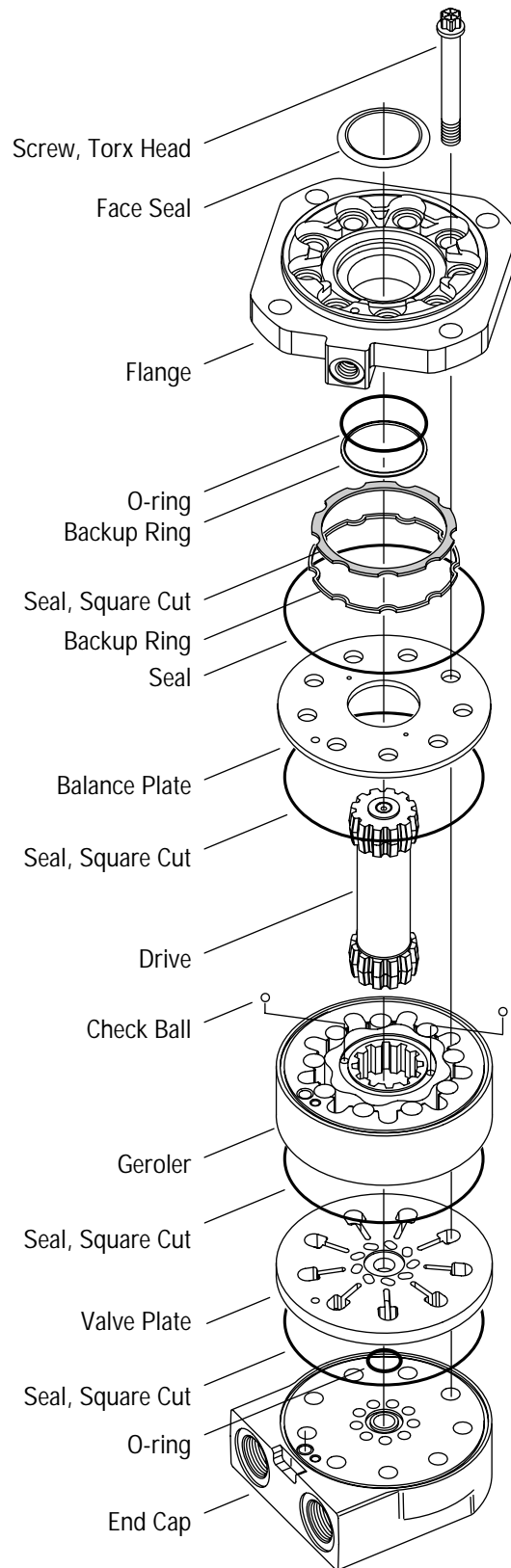
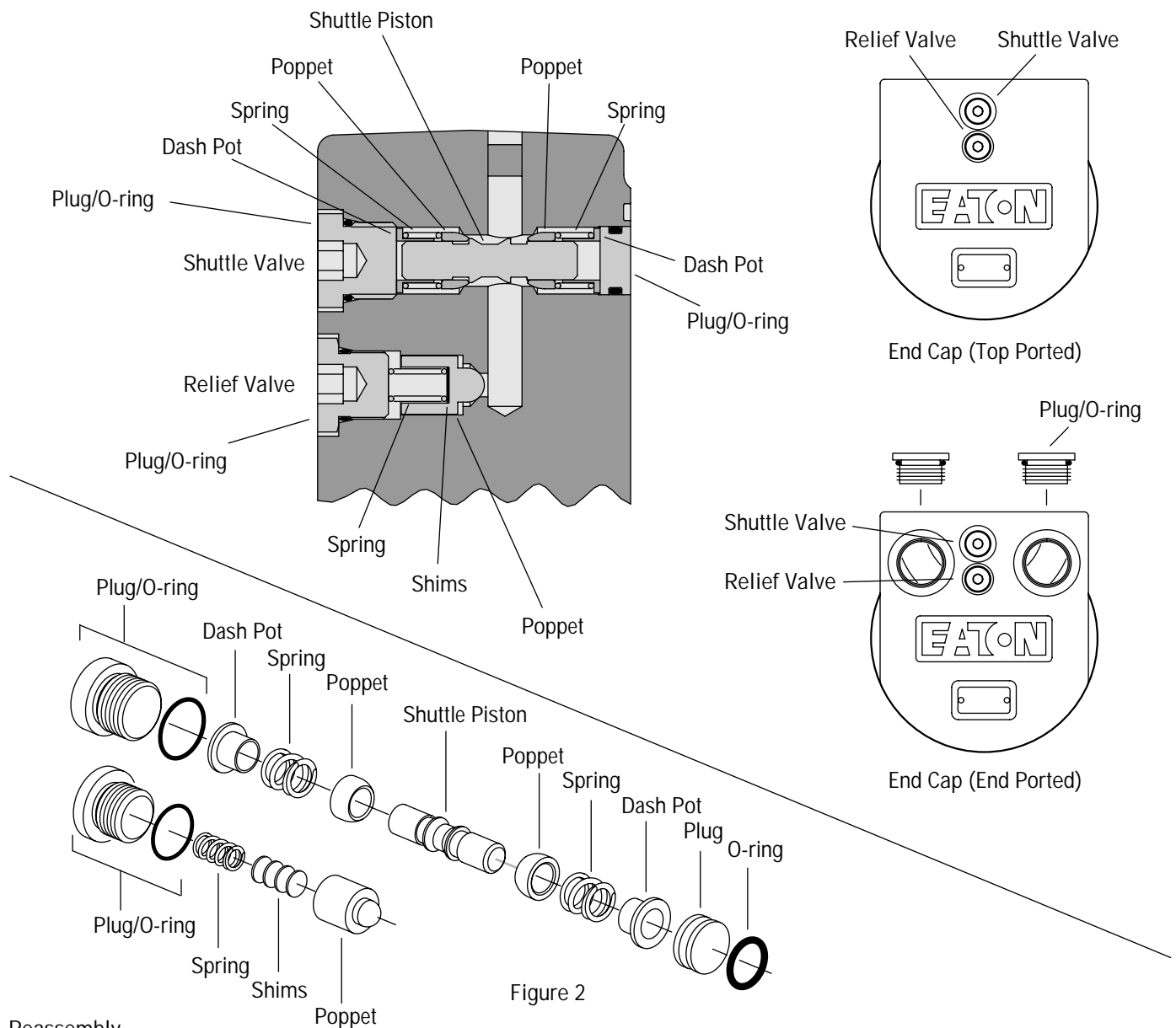

Figure 1

# 45 Series Geroler Motors



### Reassembly

Note: Always use new seals when reassembling hydraulic motors. Refer to parts list 6-153 for seal kit number, replacement parts, and ordering information.

Important: During reassembly, lubricate the new seals with a petroleum jelly such as Vaseline®. Also lubricate machined surfaces with clean hydraulic fluid.

6 Install one poppet, spring and dash pot into shuttle valve bore from valve plate side of end cap.

7 Install non-threaded plug with o-ring into end cap shuttle valve bore. O-ring and plug are to be lightly coated with petroleum jelly to ease assembly and a plug should be inserted flush with end cap mounting surface.

8 Install shuttle piston from opposite end of shuttle valve cavity.

9 Install one shuttle valve poppet, spring and dash pot onto piston.

10 Install one shuttle valve threaded internal hex plug with o-ring. Shuttle plug threads may have light coat of oil or preservative. Torque plug to 37-45 Nm [324-396 lb-in].

11 For a motor with low pressure relief valve, install poppet, shims, spring and plug. Plug threads may have light coat of oil or preservative. Torque plug to 23-29 Nm [207-253 lb-in].

12 For a motor without low-pressure relief valve, install plug with o-ring and torque plug to 23-29 Nm [207-253 lb-in].

# 45 Series Geroler Motors

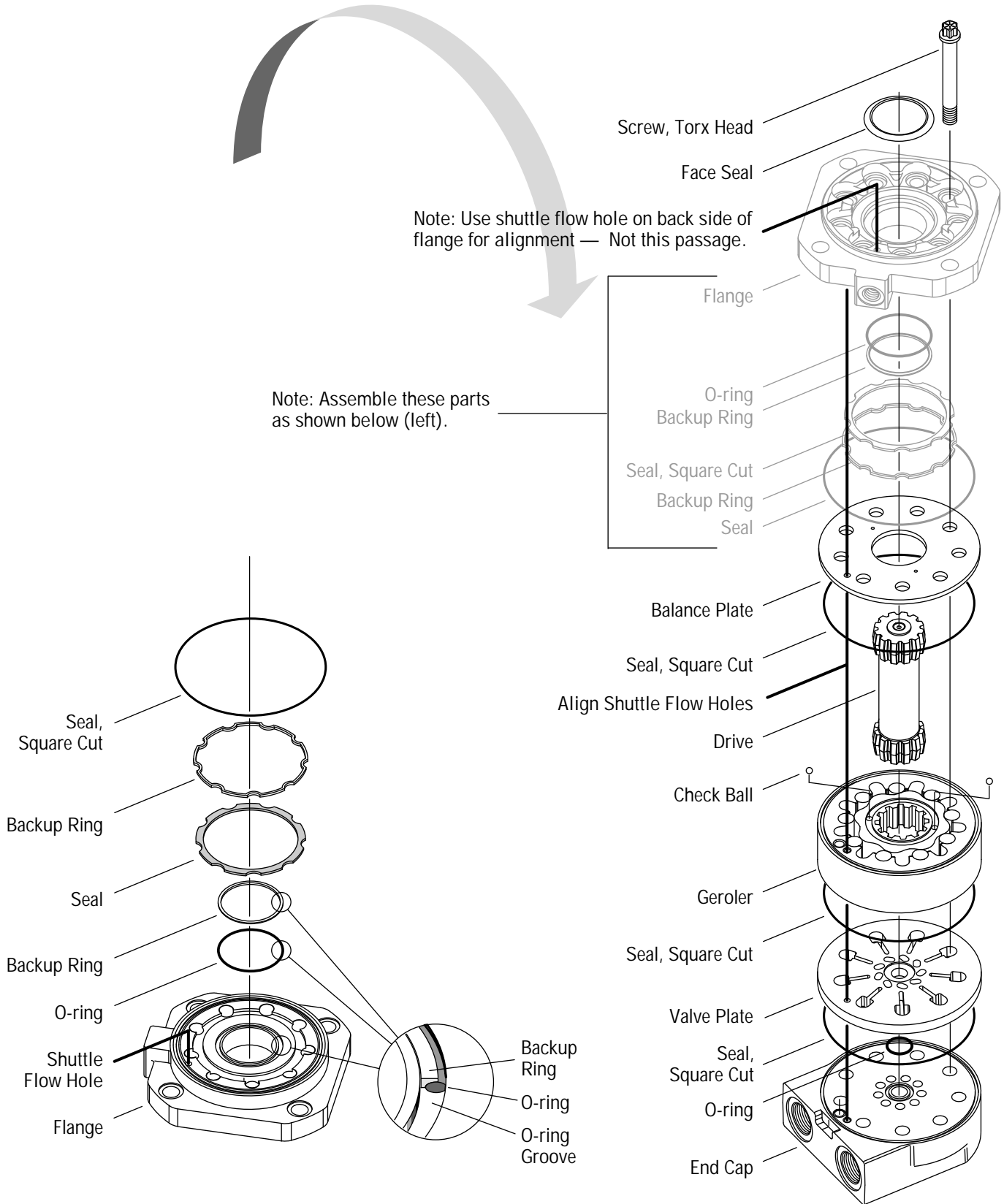

Figure 3

Figure 4

## 45 Series Geroler Motors

### Flange Assembly

Note: Backup rings and seals must have a coating of petroleum jelly to assist in retaining these parts in a inverted position later on in final assembly.

14 Position flange on work bench. With seal grooves up (see Figure 3), install square cut seal, backup ring, seal, backup ring, and o-ring in flange. Set flange assembly aside, seal side up.

### Final Assembly

15 Place end cap on work bench name tag side down, seal grooves up (see Figure 4). Install o-ring (26,7 [1.05] ID) and square cut seal (150,8 [5.94] ID) in appropriate grooves.

16 Place valve plate onto end cap. Align bolt holes and shuttle flow hole on valve plate with mating holes on end cap.

17 Install two square cut seals, one on each side of the Geroler. Seal on valve side of Geroler must have a sufficient coating of petroleum jelly to assist in retaining seal in groove.

18 Place Geroler over valve plate. Align bolt holes and shuttle flow hole on Geroler with mating holes on valve plate. Position valve side of star down and spline side up.

19 Place drive into spline of Geroler star with recessed end down.

20 Place two steel balls into seats of Geroler star (one per seat).

21 Place balance plate on Geroler. Align bolt holes and shuttle flow hole on balance plate with mating holes on Geroler.

Note: Before placing flange assembly from step 14, note the location of the shuttle flow hole. This will expedite the move from the work bench over onto the balance plate.

22 Carefully invert flange assembly and place onto balance plate with bolt holes and shuttle flow holes in line. Do Not displace seals and backup rings.

23 Install nine screws lubricated with DTE-26. Pre-torque each in a crisscross pattern to 61-75 Nm [45-55 lb-ft]. Finally in a crisscross pattern, tighten screws to 136-149 Nm [100-110 lb-ft].

Note: All bearingless motors must be handled with the drive end up. Damage to the balance plate will occur if these bearingless motors are lifted by the drive.

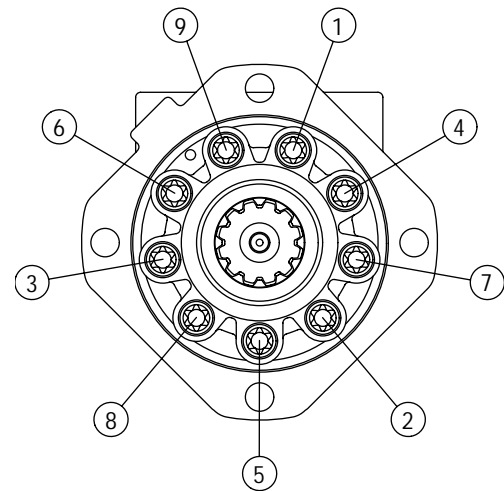

Figure 5

# 45 Series Geroler Motors

## How to Order Replacement Parts

### Each Order Must Include the Following:

1. Product Number
2. Date Code
3. Part Name
4. Part Number
5. Quantity of Parts

For More Detailed Information Contact Eaton Corp. Hydraulics Division 15151 Highway 5 Eden Prairie, MN 55344.

- Specifications and Performance Data, Catalog No. 11-112.
- Replacement part numbers and kit information — Parts Information No. 6-153.

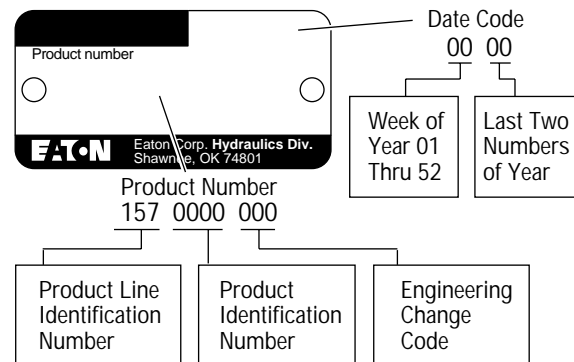

Eaton Corporation  
Hydraulics Division  
15151 Hwy. 5  
Eden Prairie, MN 55344  
Telephone: 612/937-9800  
Fax: 612/937-7130

Eaton Ltd.  
Hydraulics Division  
Glenrothes, Fife  
Scotland, KY7 4NW  
Telephone: +44 (0)1592-771-771  
Fax: +44 (0)1592-773-184

Eaton GmbH  
Hydraulics Products  
Am Schimmersfeld 7  
40880 Ratingen, Germany  
Telephone: +49 (0)2102-406-830  
Fax: +49 (0)2102-406-800

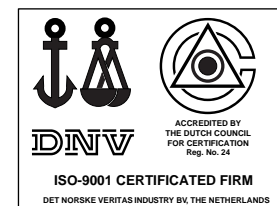

Quality System Certified  
Products in this catalog are manufactured  
in an ISO-9001-certified site.

<http://www.eaton.com>

Copyright Eaton Corporation 1996  
All Rights Reserved  
Printed in USA

Form No. 7-151