

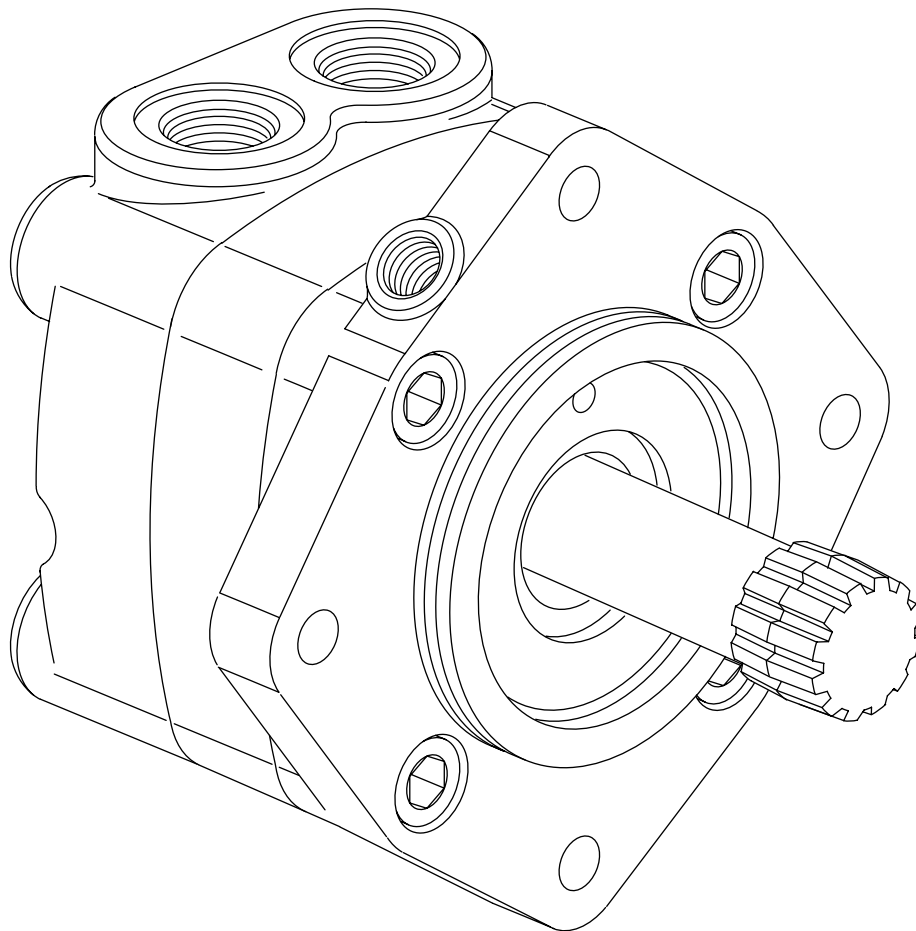

Repair Information



25 Series
VIS Bearingless Motor

001 002

25 Series Geroler Motors

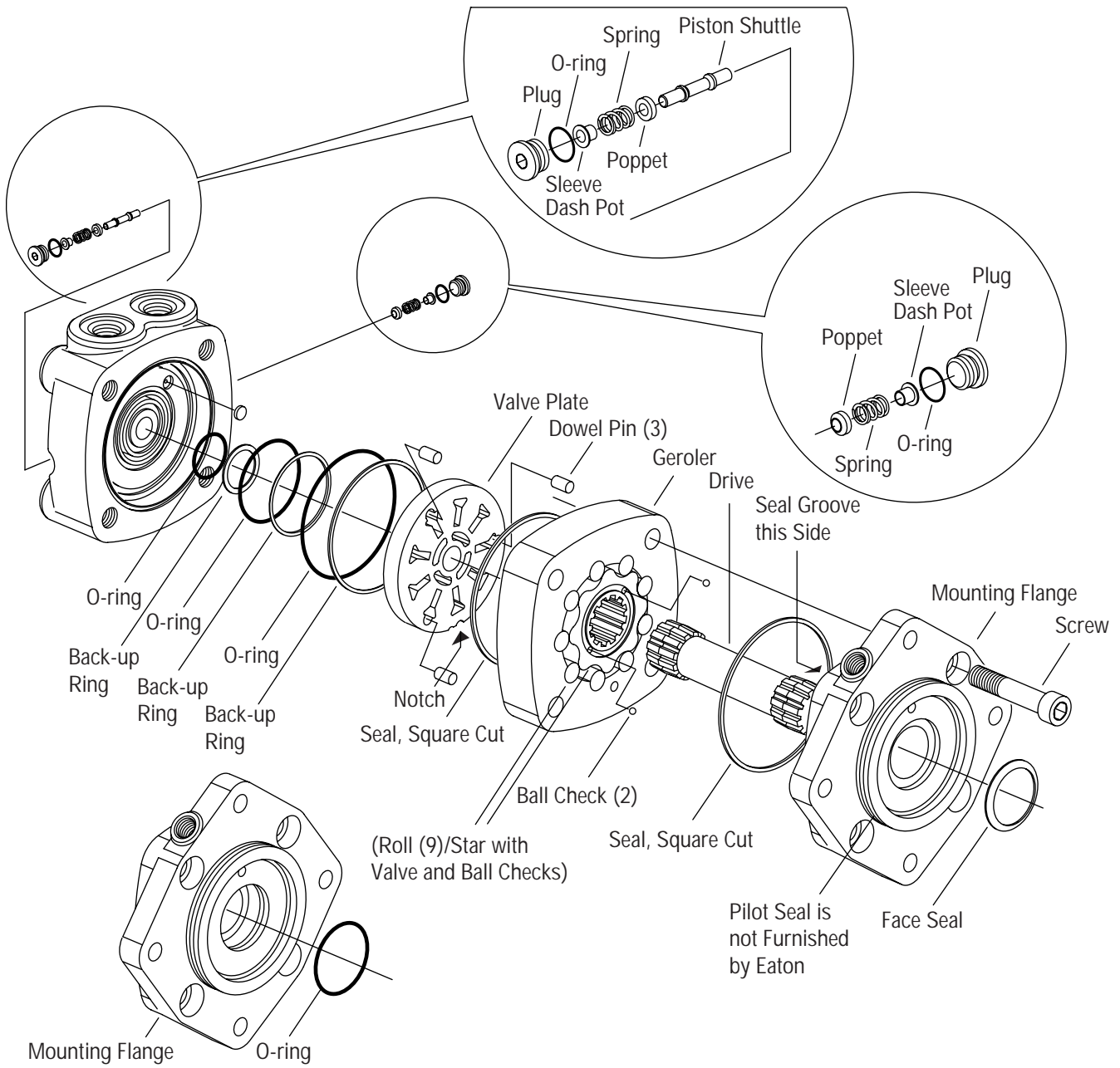

Figure 1

Tools Required

- 1/4 in. hex key
- 1/2 in. hex key
- Torque wrench - 200 Nm [150 lb-ft] capacity

25 Series Geroler Motors

1 Cleanliness is extremely important when repairing hydraulic motors. Work in a clean area. Before disconnecting the hydraulic motor, thoroughly clean the exterior. Remove motor from application and drain the oil from the motor before disassembly.

2 Make a scribe mark across the motor sections. This will help get the correct alignment when the motor is reassembled.

3 Remove the four cap screws and disassemble the motor as shown in Figure 1. Please note ball checks could possibly escape unnoticed.

4 Check all mating surfaces. Replace any parts with scratches or burrs that could cause leakage. Wash all metal parts in clean solvent. Blow them dry with pressurized air. Do not wipe parts dry with paper towels or cloth as lint in a hydraulic system will cause damage.

Note: Always use new seals when reassembling hydraulic motors. Refer to parts list 6-151 for seal kit number, replacement parts, and ordering information.

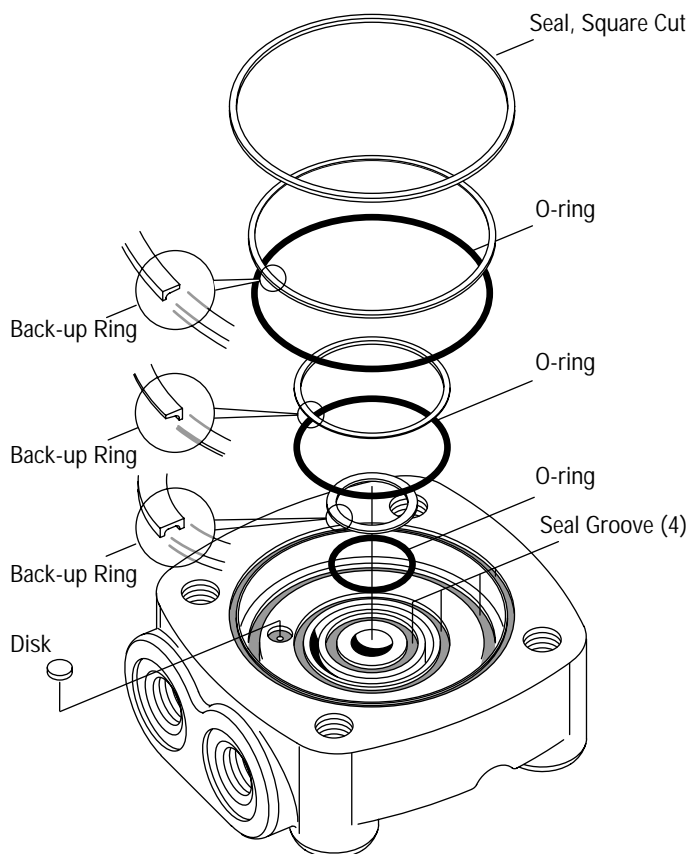

Figure 2

Important: During reassembly lubricate the new seals with a petroleum jelly such as Vaseline®. Also lubricate machined surfaces with clean hydraulic fluid.

5 Install a new o-ring (11,9 [4.7] ID) on each of the shuttle valve end plugs (2). Assemble shuttle valve parts as shown in Figure 1. Torque plugs to 41 Nm [360 lb-in].

6 Lubricate (26,7 [1.05] ID) o-ring, install in smallest of four seal grooves in end cover (see Figure 2).

7 Lubricate back-up ring and place flat side up on the (26,7 [1.05] ID) o-ring.

8 Next lubricate and install (82,3 [3.24] ID) o-ring in the next larger size seal groove.

9 Place lubricated back-up ring flat side up on top of (82,3 [3.24] ID) o-ring.

10 Install lubricated (94,9 [3.74] ID) o-ring in the next larger seal groove.

11 Place lubricated back-up ring flat side up on top of (94,9 [3.74] ID) o-ring.

12 Place disk in recess in end cover.

13 Install valve plate in end cover over seals and back-up rings, note notch is at the bottom and 9 slots should be up.

14 Place lubricated seal (one of two square cut 114,0 [4.49] ID) in seal groove around valve plate in end cover.

15 Install three dowel pins in Geroler ring.

16 Install Geroler with valve surface of star toward the valve plate. Note: Do not let rolls and dowel pins escape during reassembly. Engage dowel pins and align bolt holes.

17 Ball checks should be placed into Geroler star.

18 Install drive spline into Geroler star spline.

19 Lubricate and install (52,1 [2.05] ID) o-ring in seal groove inside the bore of mounting flange.

20 Lubricate and install second seal of two (square cut 114,0 [4.49] ID) in seal groove of mounting flange.

21 Install mounting flange on Geroler.

22 Add four bolts and torque each to 183 Nm [135 lb-ft].

23 Shaft face seal and pilot diameter o-ring will have to be installed with mating assembly.

25 Series Geroler Motors

How to Order Replacement Parts

Each Order Must Include the Following:

1. Product Number
2. Date Code
3. Part Name
4. Part Number
5. Quantity of Parts

For More Detailed Information Contact Eaton Corp. Hydraulics Division 15151 Highway 5 Eden Prairie, MN 55344.

- Replacement part numbers and kit information — Parts Information No. 6-151.

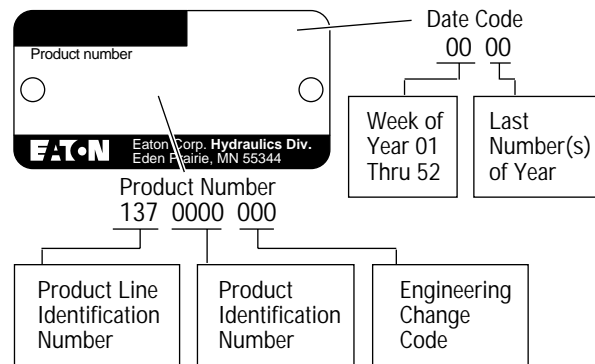

Eaton Corporation
Hydraulics Division
15151 Hwy. 5
Eden Prairie, MN 55344
Telephone: 612/937-9800
Fax: 612/937-7130

Eaton Ltd.
Hydraulics Division
Glenrothes, Fife
Scotland, KY7 4NW
Telephone: +44 (0)1592-771-771
Fax: +44 (0)1592-773-184

Eaton GmbH
Hydraulics Products
Am Schimmersfeld 7
40880 Ratingen, Germany
Telephone: +49 (0)2102-406-830
Fax: +49 (0)2102-406-800

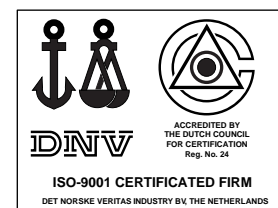

Quality System Certified
Products in this catalog are manufactured in an ISO-9001-certified site.

<http://www.eaton.com>

Copyright Eaton Corporation 1996
All Rights Reserved
Printed in USA

Form No. 7-149

